

BOUNCE
MONIKA MULDER
STOCKHOLM 2019

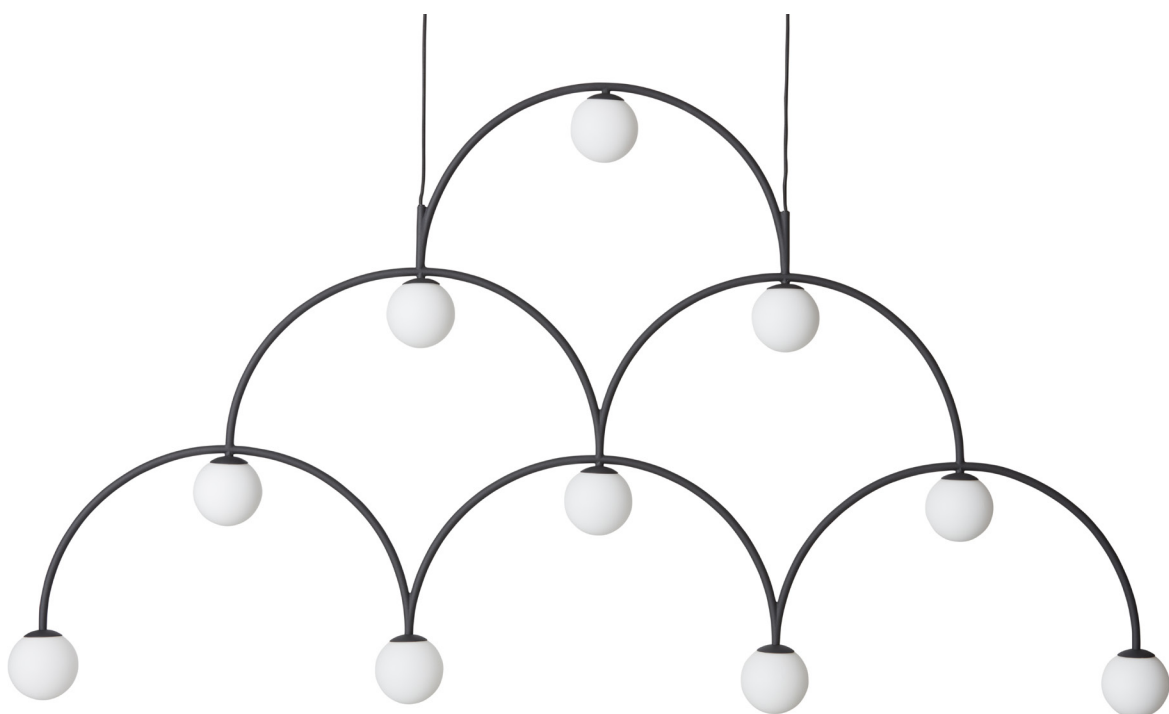

pholc

pholc

Stockholm 2019-02-05

PRESSCONTACT

SWEDEN

Tres PR

info@trespr.se

+ 46 70 983 88 55

PHOLC

maja@pholc.se

pholc.se

+46 73 642 96 22

For high-res images:

Email Tres PR or Pholc

or download at

www.pholc.se/imagebank

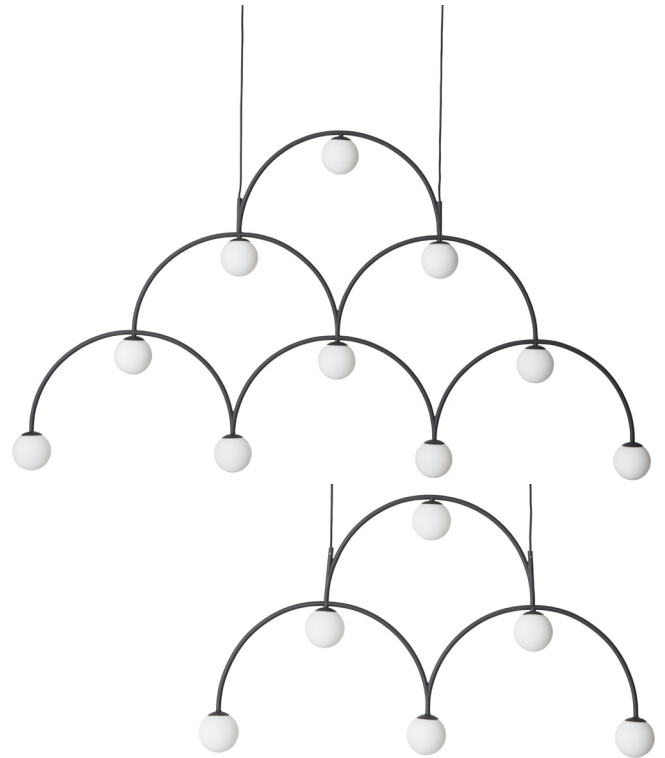

BOUNCE MONIKA MULDER STOCKHOLM 2019

The pattern that Bounce creates is energetic, graphic and bouncy. A positive graphic feeling.

I wanted to create a lamp that gives the room character and at the same time gives light. With that in mind, I created a graphic expression with a focus on the path the electricity is drawn from light spot to light spot.

The result is a flat, screen-like luminaire that fits well over oblong tables or counters.

ABOUT MONIKA MULDER

Dutch designer Monika Mulder (1972) cares a lot for the sculptural aspect of design. In her eyes everything is a composition. Monika's main interest is to develop relevant solutions for real needs, and to give grace and beauty to everyday products. Her work is playful and functional, solving challenges of production with creativity and consideration.

Monika's designs have received awards such as Best Swedish design 2001 and Elle Decoration Best furniture of the Year 2003. And her work has been shown on exhibition world wide as well as published in design books.

Monika was born in Woudsend. She studied at the Design Academy in Eindhoven. An internship at the design department of IKEA led to a job and a succession of notable projects. In 2007 she set up her design studio in Gothenburg, where she works as an independent designer.

PHOTO: KIMME PERSSON

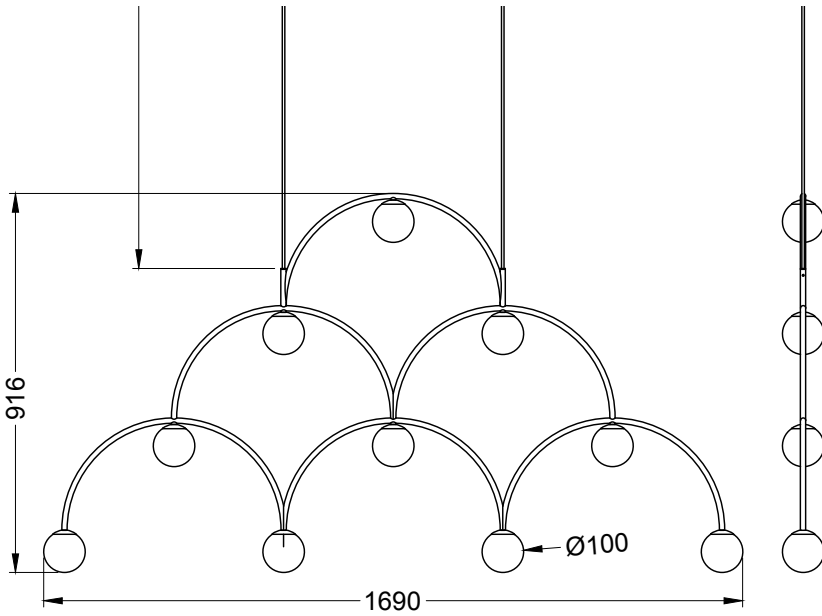

BOUNCE 169
515 105 - BLACK. OPAL GLASS
METAL. GLAS
DIMENSIONS
W:10 L:169 H:91
LIGHTSOURCE
G9 * 10
NOT INCLUDED

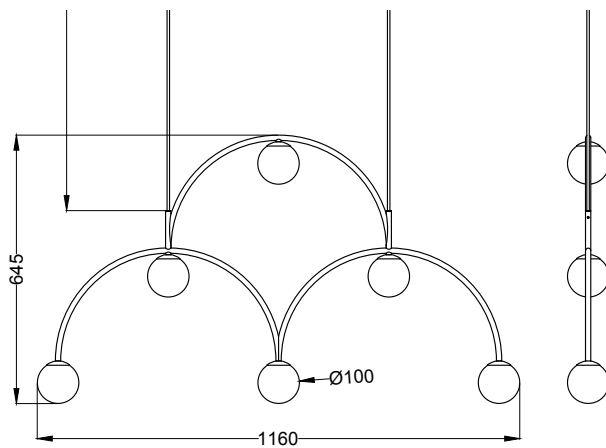

BOUNCE 116
514 165 - BLACK. OPAL GLASS
METAL. GLAS.
DIMENSIONS
W:10 L:116 H:65
LIGHTSOURCE
G9 * 6
NOT INCLUDED

DONNA
NINA JOBS & STINA SANDWALL
STOCKHOLM 2019



pholc

pholc

Stockholm 2019-02-05

PRESSCONTACT

SWEDEN

Tres PR

info@trespr.se

+ 46 70 983 88 55

PHOLC

maja@pholc.se

pholc.se

+46 73 642 96 22

For high-res images:

Email Tres PR or Pholc

or download at

www.pholc.se/imagebank



DONNA
NINA JOBS & STINA SANDWALL
STOCKHOLM 2019

The pendant lamp Donna gives a feeling of soft pleated textile although the material is of thin metal.

We were inspired of material in fashion, chic ladies and the challenge to transform a hard material into a soft feeling!

Versatile when it comes to usage and both beautiful at home and in public spaces

ABOUT
NINA & STINA

STINA SANDWALL

Stina's product design is characterized by a balance between function and a clear design aesthetics. The dialogue with the client has always been an important and inspiring part of her design process.

After graduating from Beckmans School of Design in 1999 Stina Sandwall set up here own design studio in Stockholm. Her work has received attention with awards such as "Excellent Swedish Design" as well as "Elle Decoration Swedish Design Award".

NINA JOBS

Nina Jobs started her design business in Stockholm 2002 after several years of study in Paris.

She has created a company that has become a platform for a wide range of work, covering products, furniture design, art direction and visual performance. The cornerstones of the company's strategy are a request for simplicity, sustainability and timeless design. Nina's work has been published worldwide and received international design awards

PHOTO: KIMME PERSSON

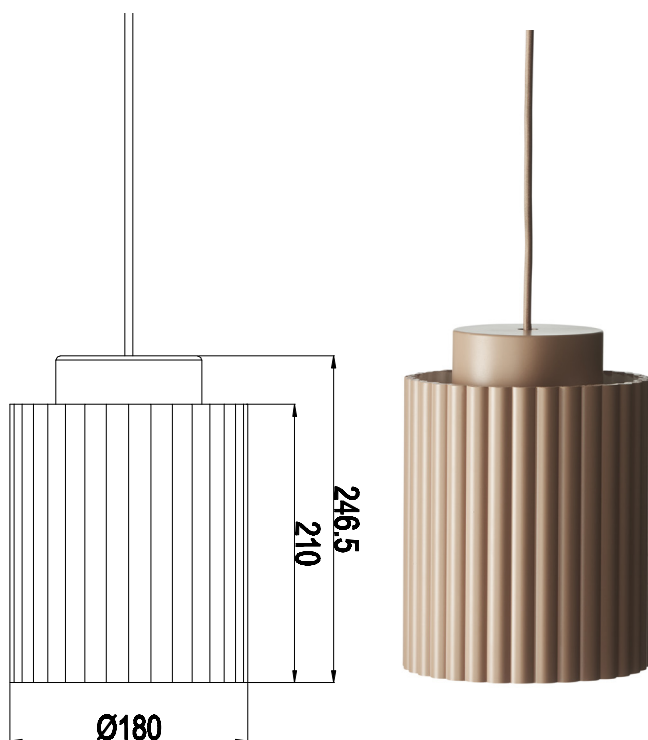

DONNA 18

961 113 - LINEN
 961 114 - BLUSH
 961 115 - BLACK INK
 961 118 - AUTUMN LEAVES
 ALUMINIUM

DIMENSIONS
 D:18 H:25

LIGHTSOURCE
 E27
 DIFFUSER

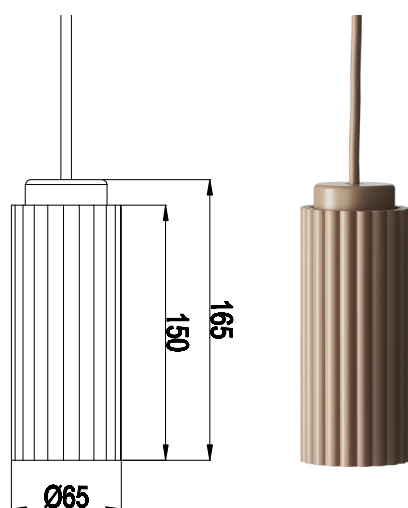

DONNA 7

960 113 - LINEN
 960 114 - BLUSH
 960 115 - BLACK INK
 960 118 - AUTUMN LEAVES
 ALUMINIUM

DIMENSIONS
 D:7 H:17

LIGHTSOURCE
 G9
 REFLECTOR



KANDINSKY
BROBERG & RIDDERSTRÅLE
STOCKHOLM 2019

pholc

pholc

Stockholm 2019-02-05

PRESSCONTACT

SWEDEN

Tres PR

info@trespr.se

+ 46 70 983 88 55

PHOLC

maja@pholc.se

pholc.se

+46 73 642 96 22

For high-res images:

Email Tres PR or Pholc

or download at

www.pholc.se/imagebank



KANDINSKY BROBERG & RIDDERSTRÅLE STOCKHOLM 2019

This pendant lamp is inspired by the abstract circle paintings by Wassily Kandinsky during his years at the renowned Bauhaus school in the 1920's. A sphere and a spear act as the main characters in the lamp composition, piercing each other in midair to create an object that evokes a sensation of weightlessness, fragility and precision.

The custom-made light source is shaped and fitted seamlessly as a part of the brass spear and emits a glowing, dimmable light from the center of the smoke-colored glass.

The Kandinsky lamp is available in two sizes with a 300 or 450mm wide glass bubble. It functions well as a lamp or object to set the mood of a room, hanging in numbers in a large space or as a single piece over a table.

ABOUT BROBERG & RIDDERSTRÅLE brda.se

Mats Broberg and Johan Ridderstråle are creative collaborators based in Stockholm, Sweden, working in a mixed architecture and design practice. They strive to add an emotional value to our design that communicates with the user through recognition of symbols and meanings. They often draw inspiration from everyday life and try to combine a rational approach with a bit of wit and the clash between past and present.

Both Mats and Johan graduated from Konstfack University of design with honors and have been awarded the Swedish Art Council's working grant. Their work has been exhibited in Tokyo, Milan and London.

PHOTO: KIMME PERSSON

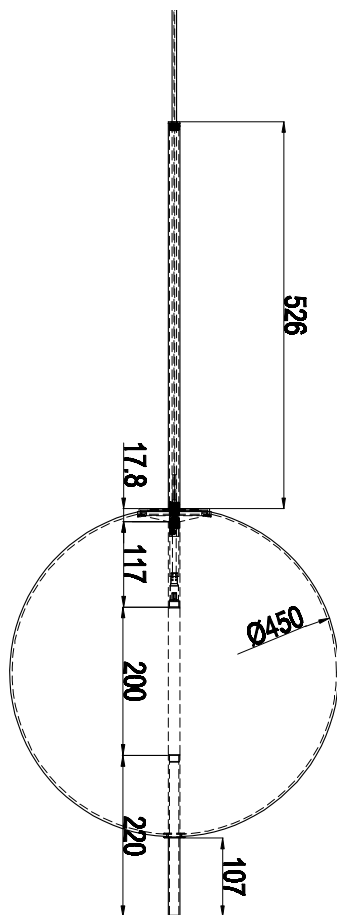

KANDINSKY 45

518 119 - BRASS. SMOKED GREY
518 112 - BRASS. SMOKED BROWN

HAND-BLOWN GLASS
BRASS

DIMENSIONS
D:45 H:108

LIGHTSOURCE
W:6. LM:500. K:2700
DIMMABLE
EXCHANGABLE

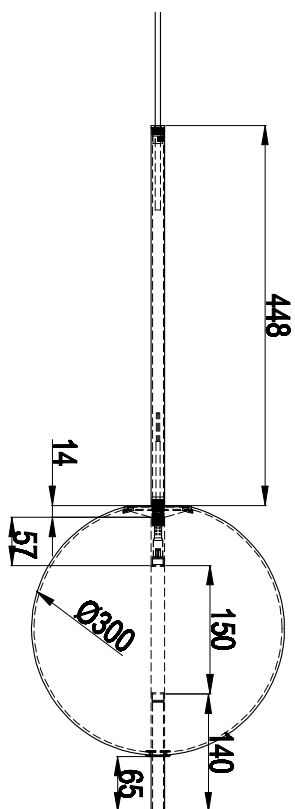

KANDINSKY 30

517 119 - BRASS. SMOKED GREY
517 112 - BRASS. SMOKED BROWN

HAND-BLOWN GLASS
BRASS

DIMENSIONS
D:30 H:80

LIGHTSOURCE
W:5. LM:417. K:2700
DIMMABLE
EXCHANGABLE